

LIQUI-FLOW™ mini

Micro Fluidic Mass Flow Meters for Liquids

> Introduction

Bronkhorst High-Tech B.V. has been the pioneer in the field of micro to low flow liquid metering instruments based on a thermal measuring principle. A wealth of experience has been gathered over many years, which has resulted in a series of instruments covering Full Scale flow ranges from 75 mg/h up to 20 kg/h.

> Micro fluidic concept

The use of micro fluidic devices for research and analytical purposes has some important advantages. Firstly, because the internal volumes within the instruments are very small, the analysis will be faster and the amount of reagents and analytes used can be reduced. The latter is especially significant for expensive reagents. Furthermore, the physical dimensions are much smaller than those of conventional devices. This enables Life Sciences system integrators to downscale the size, inherently reducing the costs of ownership, of their equipment. Also, the availability of compact and lightweight instruments could lead to the development of portable systems.

> LIQUI-FLOW™ mini for liquids

Bronkhorst designed the LIQUI-FLOW™ mini Mass Flow Meter (MFM) for liquids according to the micro fluidic concept. This very compact instrument measures ultra low flow ranges from 1,5...75 mg/h (0,025...1,25 µl/min) up to 12...600 mg/h, based on water. The straight, duplex steel sensor tube (W1.4462) has an internal volume of less than 1 mm³ and operates on the thermal measuring principle. Due to its high pressure rating (up to 1000 bar; higher on request) the MFM is suited to HPLC systems. The instrument is equipped with a microprocessor-based printed circuit board, offering high accuracy and excellent temperature stability. The RJ45 connection is used for power supply and for both analog and digital (RS232/RS485) communication.



Actual size

> Features

- ◆ compact assembly ensures space efficiency
- ◆ very small internal sensor volume (0,88 mm³; smaller on request) for fast analysis
- ◆ high accuracy and repeatability
- ◆ insensitive to mounting position
- ◆ high pressure rating (PN1000; higher on request)
- ◆ easy cleaning due virtually no dead volume
- ◆ straight sensor tube reduces risk of clogging

> Applications

- ◆ (Bio)medical laboratories
- ◆ Food & Pharmaceutical industry
- ◆ Analytical laboratories and systems (HPLC)
- ◆ Flow chemistry using microreactors

> Technical specifications

Performance specifications

Flow capacity (typical)	: H ₂ O: min. 1,5...75 mg/h max. 12...600 mg/h
Accuracy	: < ± 2% FS
Turndown	: 1:50
Operating temperature	: 5...50°C
Temperature sensitivity	: 0,1% RD/°C + 0,15 mg/h/°C
Repeatability	: < ± 0,2% FS
Reproducibility	: < ± 0,5% FS
Response time	: $\tau_{63\%}$ = 0,4 sec.
Pressure drop (at 1 cP)	: < 0,5 mbard
Max. pressure	: 1000 bar (higher on request)
Viscosity	: 0,1...100 cP
Attitude sensitivity (at 90°)	: < ± 3 mg/h
Warming up time (approx.)	: 10 min. for 2% accuracy

Mechanical specifications

Seals	: Metal
Material of construction (wetted parts)	: Duplex steel, W1.4462
Weight	: 0,15 kg
Fittings	: none (10-32 UNF Female); option: 1/16" OD (PEEK or SS316)

Electrical specifications

Electrical supply voltage	: 15...24 Vdc, min. load impedance > 2 kΩ
Analog output	: 0...5 (10) Vdc, max. load imp. < 375 Ω : 0 (4)...20 mA (sourcing output)
Digital communication	: RS232 or RS485 (Modbus RTU/ASCII or FLOW-BUS)
Power consumption (approx.)	: 1 Watt
Electrical connection	: RJ45 modular jack
Ingress protection	: IP40

Calibration

References	: Verified by VSL, the Dutch calibration organisation, and traceable to Dutch and international standards.
Liquids	: Standard calibration fluids: H ₂ O or IPA (Isopropyl Alcohol); for other liquids apply to factory.
System	: Precision laboratory balances.

Technical specifications and dimensions subject to change without notice.

> Dimensions (mm)

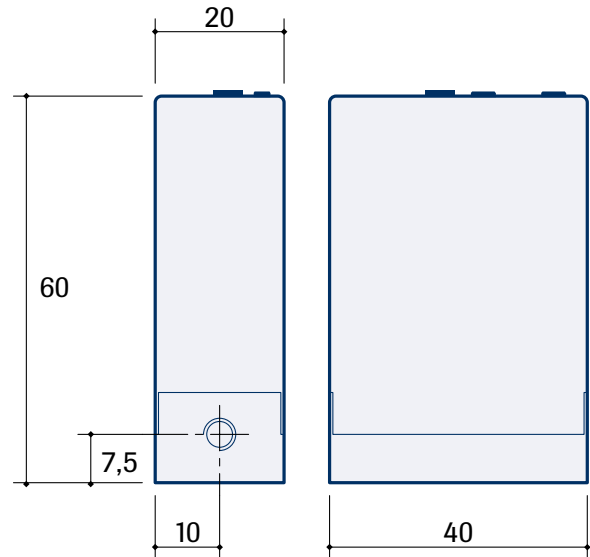

> Model number identification

